

# 6. Troubleshooting

## 6-1 Checkpoints by Error Mode

- 1. Power Light: Check the master switch (ON/OFF) and the fuse to see if they are operating.
- 2. LED Blinking: See the basic LED checklist in 6-2-1

< Blinking Temp & Timer LED >

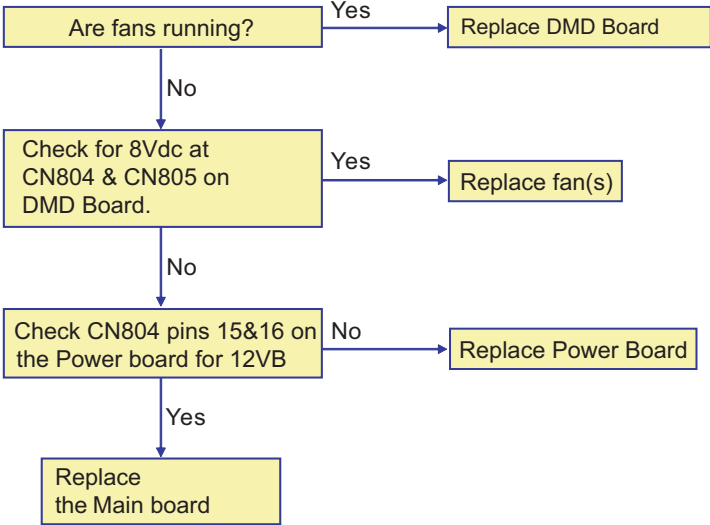

< Blinking Lamp and Temp LEDs >

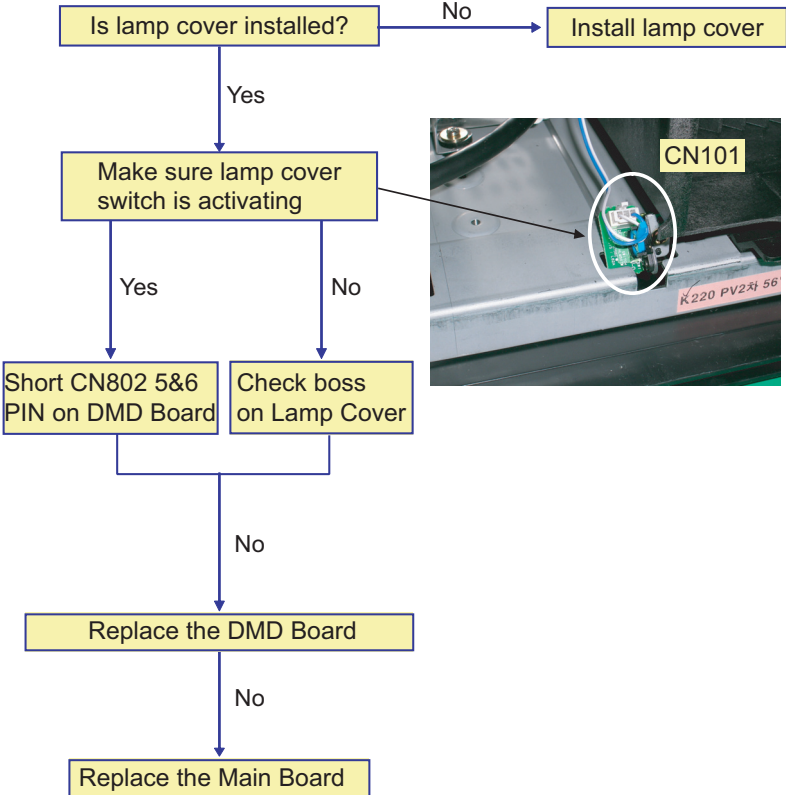

< Blinking Temp LED >

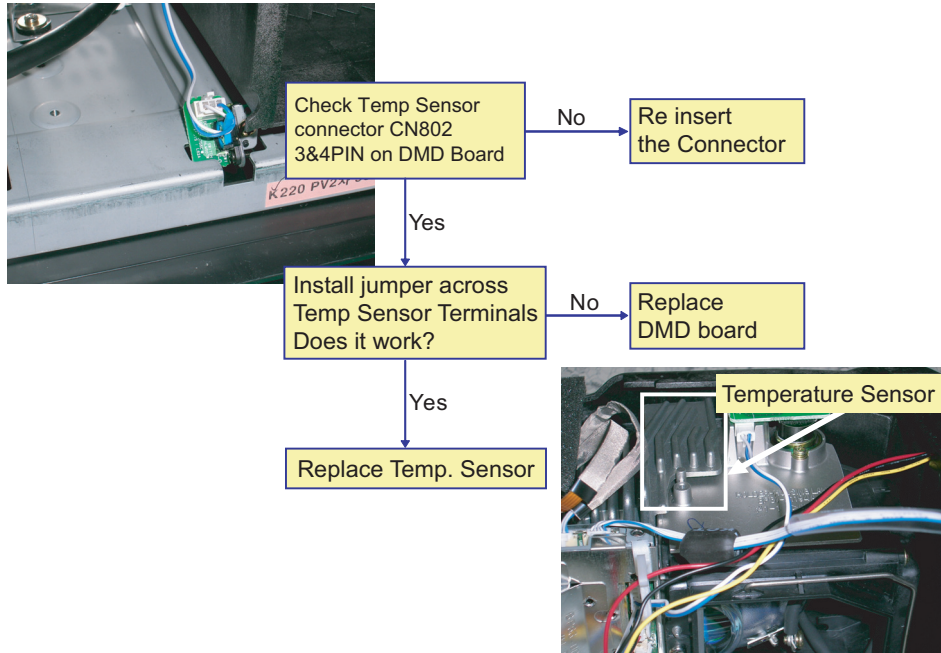

A blinking lamp LED is the most common failure indication. It can be caused by no lamp, no color wheel, no fan(s), or other defective components.

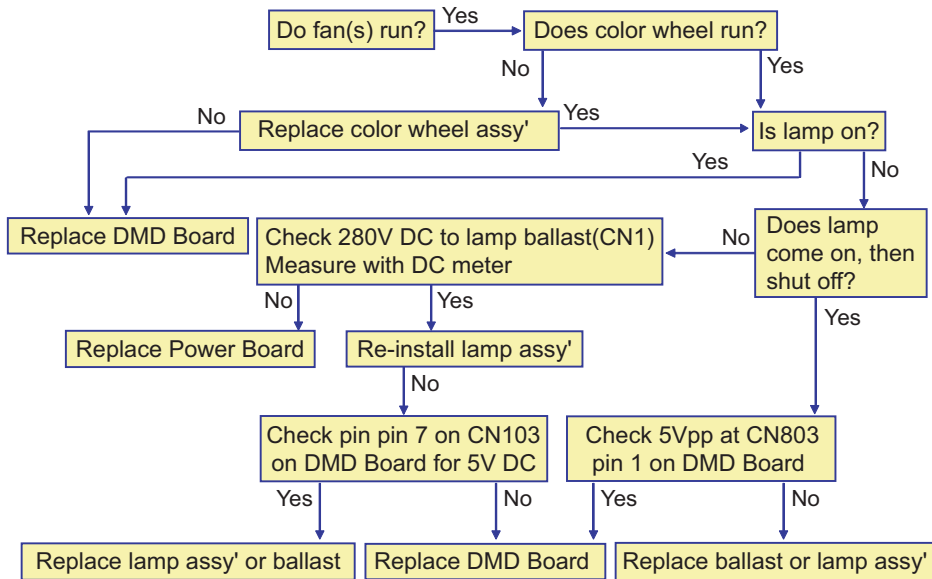

### 3. Noise:

Internal noise may be caused by a foreign substance on the fan or driving device.

For a DLP TV, the lamp fan, DMD board fan and color wheel are vulnerable to noise. Sometimes the connector wire around the lamp or DMD fan makes contact with the fan, while the color wheel is protected inside the module and cannot make contact with any nearby wires. However the color wheel sensor or the drive motor may cause noise by making contact with the color wheel.

As the color wheel uses an air bearing system, it has a very slight possibility of creating internal noise.

When irregular noise occurs for no particular reason, check the inside of the TV for any foreign substances.

The DLP projection TV may cause noise as the physical screen is empty inside, causing a resonance to a particular frequency.

Thus a low vibration is not a malfunction.

Any 'creaking' noise is mostly from the structure of the device itself. A short, harsh noise may occur from a distortion or malformation due to thermal expansion between the metal joints, screws and loaded parts, respectively. Any intermittent 'creaking' noise can be removed by loosening the screws.

### 4. Black Screen (Voice Output): Replace the DMD board

5. A black screen with the lamp on: Replace the DMD board.

6. Line Pattern: Regular line patterns occur vertically or horizontally: Replace the DMD board.

7. Voice Distortion: Replace the main board.

8. Outside Light: This is not a product malfunction, but a possible installation or human error. This occurs when the projected light from the surrounding illumination reflects onto the screen. This disappears as the TV starts operating and the TV lamp gets brighter. However, you can avoid outside light by changing the position of the TV or the installation angle.

Decreasing the illumination or changing the indoor lighting may work.

### 9. Screen Flip-over:

Enter Factory mode in DDP3021 and perform H-Flip (flip horizontally) and V-Flip (flip vertically).

The screen will flip over horizontally or vertically.

10. Other Screen Errors:



- ▶ 40 Vertical lines 16 pixels wide:  
DDP3021 or BGA, DMD panel interference.  
→ Replace the DMD board

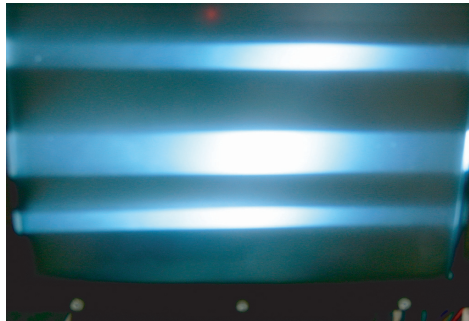

- ▶ Horizontal Bar or No Raster:  
Error in DDP3021 or the DMD panel.  
→ Replace the DMD board



- ▶ Dotted Vertical Bar:  
Error in Rambus Dram(IC301) or the soldering  
→ Replace the DMD board

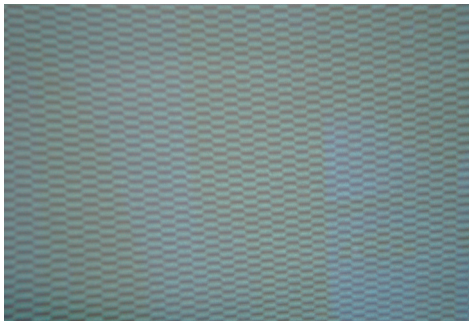

- ▶ Beehive mosaic patterns all over the screen:  
Error in the LVDS Receiver (IC100) or the soldering  
The H sync signals are not transferred to DDP3021.  
→ Replace the DMD board.

## 6-1-1 Video Circuit Error Checking

### ■ Basics:

- The DDP3021 on the DMD board has a feature to display internal test patterns.
- DNle, which is an end port in the main board, has a feature to display internal test patterns.
- The X240H is the first output and the DNle output is the second one, followed by DMD, which is the final one.
- The video path flow : RF/External input → X240 → DNle → DDP3021.

### ■ Diagnosis By Module

#### 1. Access Service Mode

(In Standby mode, press "Mute", "1", "8", "2" and "Power" to turn the screen on and enter service mode)

#### 2. Check if there is an error in the DMD board

DDP3021 → TEST PATTERN → Press the right arrow key:

Options of FULL WHITE, BLACK, RED, GREEN and BLUE PATTERN and so on are displayed on the screen.

If "Pattern" does not appear, this is a DMD board error.

#### 3. Check if there is an error in the Main board

Factory mode → DNle → TEST PATTERN → Press the right arrow key

If "pattern" does not appear, this is a Main board error. Replace Main board.

#### 4. Check if there is an error in the main board.

Check for a power signal from SMPS to other board see the schematic diagram(10-1) And check for indicated power signal.

### 6-1-2 Flow Chart for Malfunction

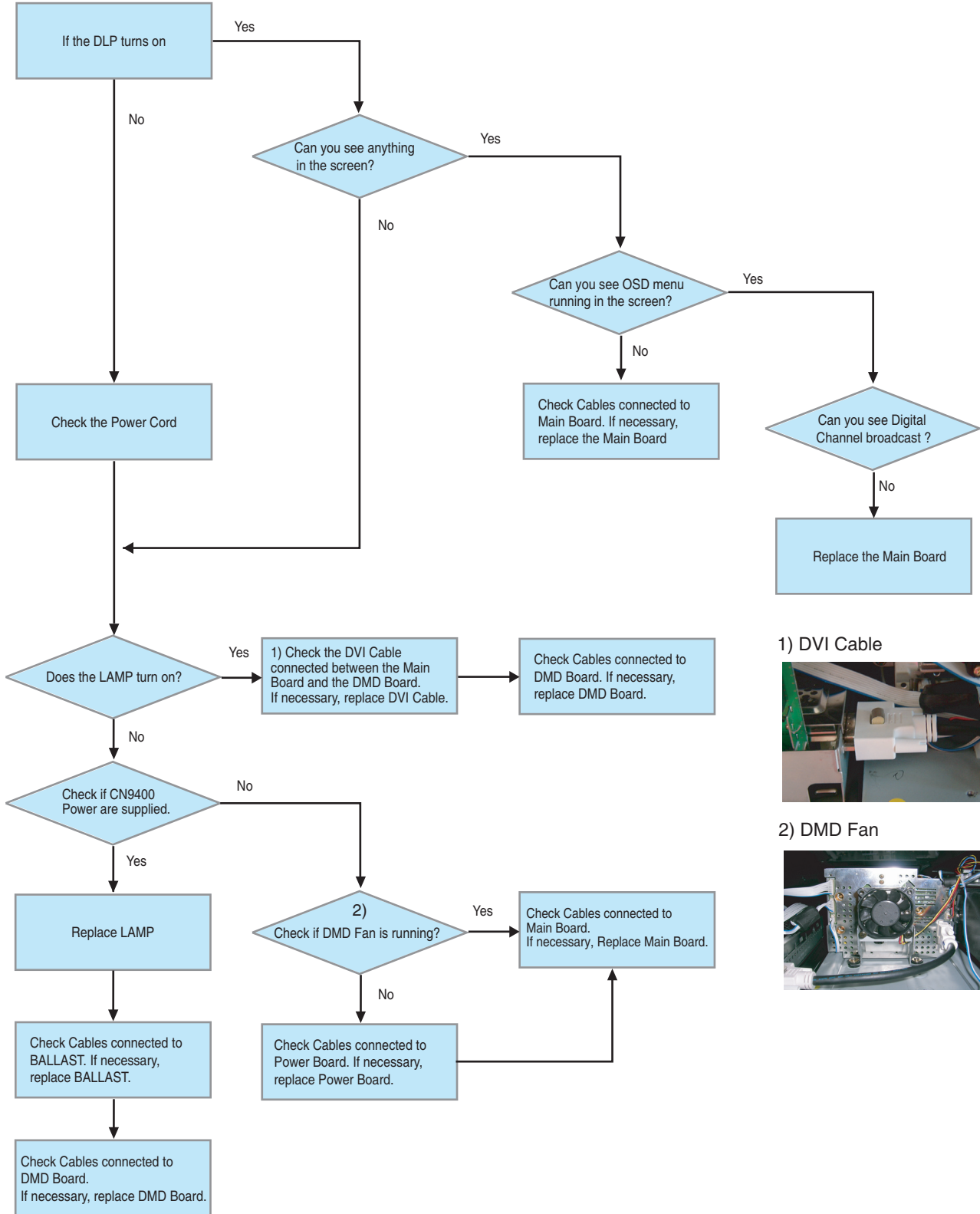

1) DVI Cable

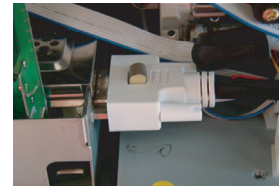

2) DMD Fan

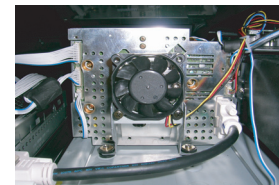

## 6-2 Troubleshooting Procedures by Error Modes

### 6-2-1 Installation & Connection

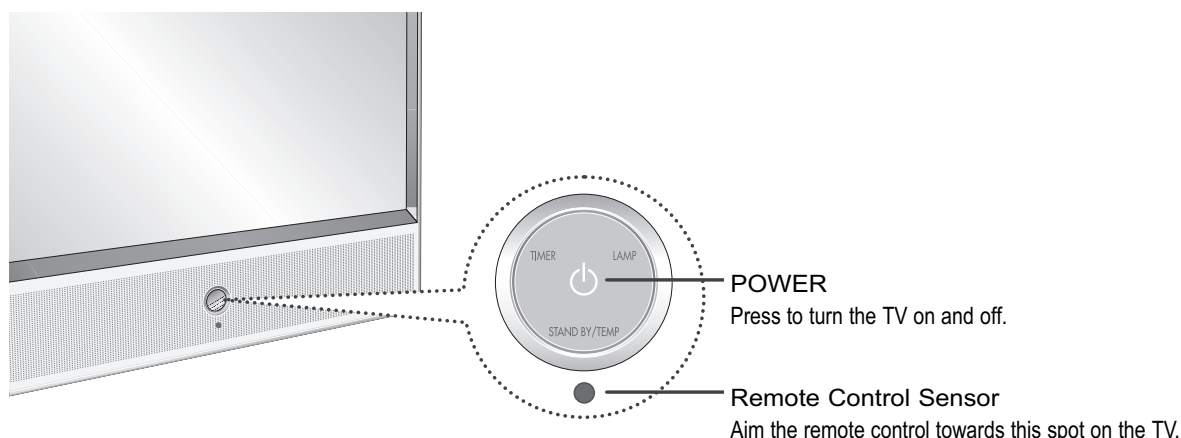

- : Light is On
- ◐ : Light is Blinking
- : Light is Off

TIMER	LAMP	STAND BY/TEMP	Indication
○	○	●	Standby state.
○	◐	○	The picture will automatically appear in about 15 seconds.
●	◐	○	Auto Timer ON/OFF has been set and the set will automatically be turned on in about 15 seconds.
◐	○	◐	A cooling fan inside the set is not operating normally.
○	◐	◐	Lamp cover on rear of the set is not properly shut.
○	○	◐	Check if the ventilation hole on the rear of the set is blocked, because if the inner temperature is too high, the power will shut off.
◐	◐	◐	Lamp may be defective.

- \* It takes about 30 seconds for the TV to warm up, so normal brightness may not appear immediately.
- \* The TV has a fan to keep the inside lamp from overheating. You'll occasionally hear it working.

### 6-2-2 Protect Status

#### 1. When the rear cover is opened

A sensor detects when the rear cover is opened and turns the set off and then into Standby mode.

If you close the cover or fix the switch, you can turn the set on by pressing the Power button on the unit or the remote control. The set will then operate normally.

#### 2. When the temperature sensor operates

When the set is overheated, the internal temperature sensor turns the set off and the set goes to Standby mode.

When the internal temperature of the set returns to a normal range, turn the power on by pressing the Power button on the unit or the remote control. The set will then operate normally.

#### 3. Attempting to turn the lamp on fails repeatedly

If turning the lamp on fails, the set automatically tries turning the lamp on 3 times. If all attempts fail, all LED's on the front panel will blink. Check the lamp and the ballast and replace them, if necessary.

## 6-3 Troubleshooting Procedures by ASS'Y

### 6-3-1 Check Lamp & Ballast

1. When the lamp is not on, check if there is anything wrong with the ballast.

Remove the lamp. Fix the safety switch on the right with tape and turn on the power.  
Check to see if a blue flame starts igniting in the arc gap inside the ballast momentarily during start-up.  
There is no problem with the ballast if there is a flame. When the ballast has no error, replace the lamp.

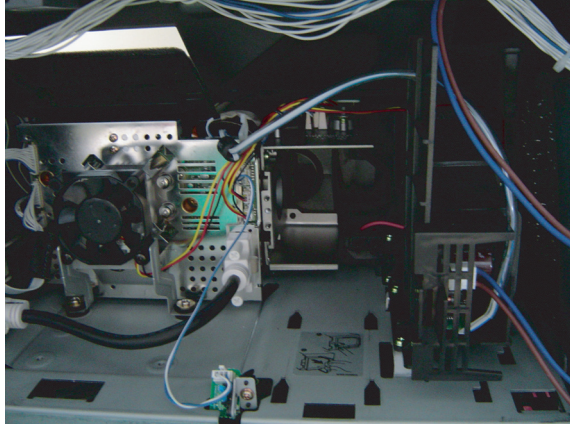

A blue flame occurs momentarily during start-up.

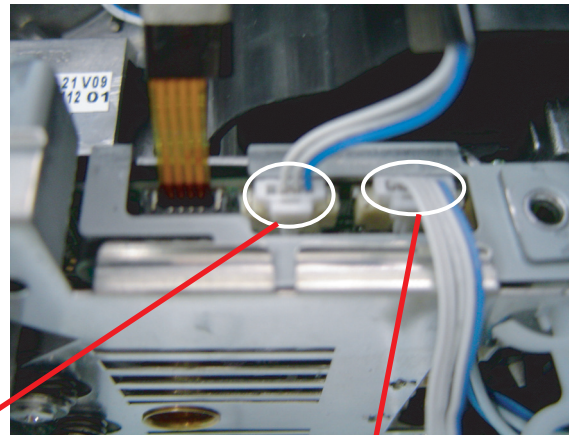
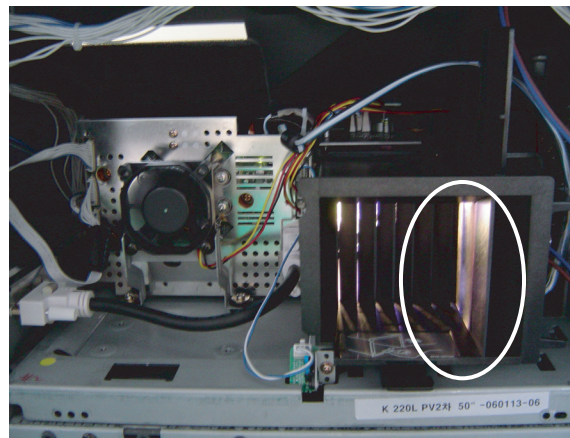
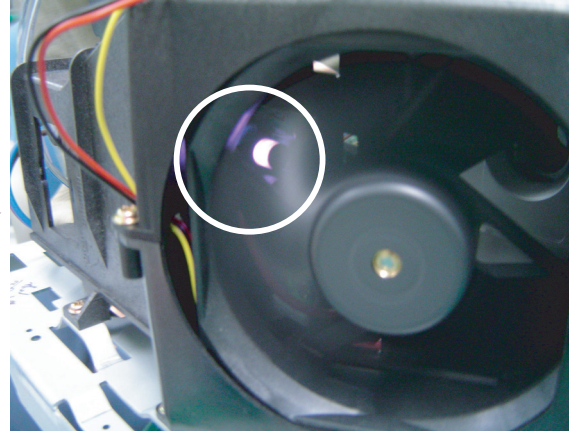

3.5V 240Hz

5V 120Hz

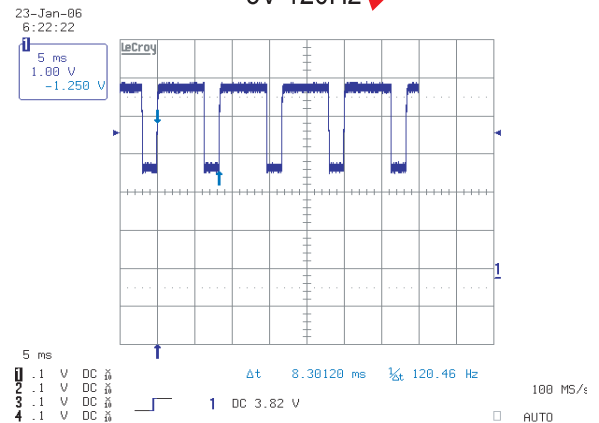
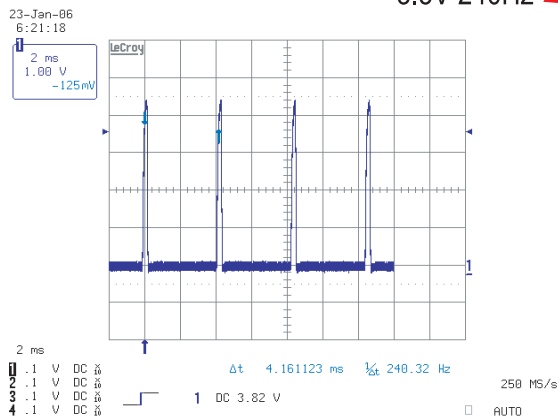



### 6-3-2 When the lamp and the ballast are normal but the lamp does not turn on or turns off right after quickly lighting up

- 1. Check the color wheel
  - Check if the color wheel is running. + Check the DMD board and the ballast for the signals.
  - Check the second CN800 pin for input signals. When 3.5V, 240Hz is output, the color wheel is operating normally.

#### COLOR WHEEL SENSOR DETECTION

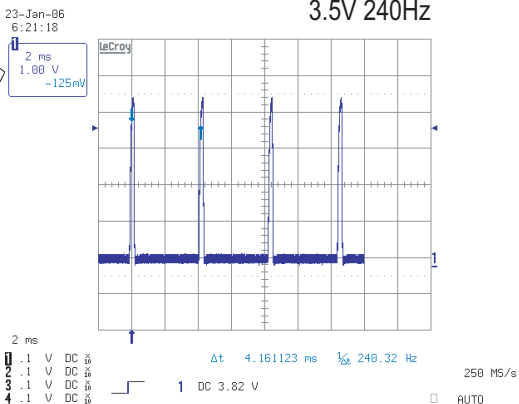
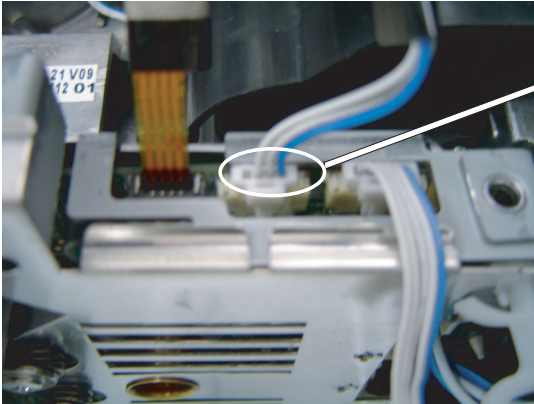
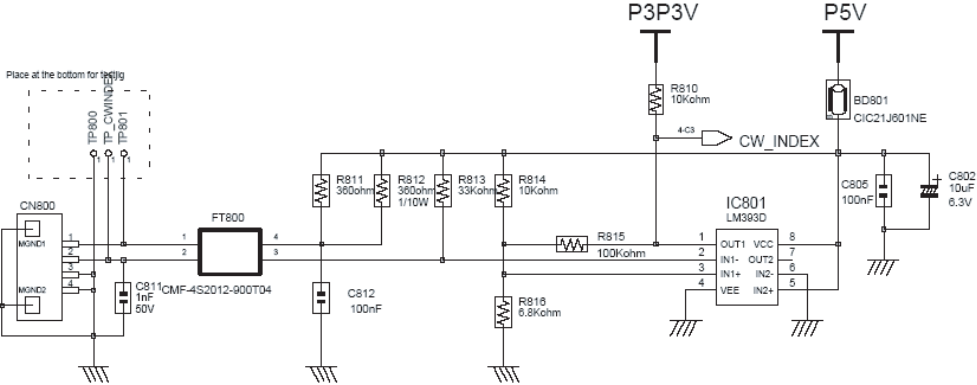

#### ※ DMD Board Check Diagram

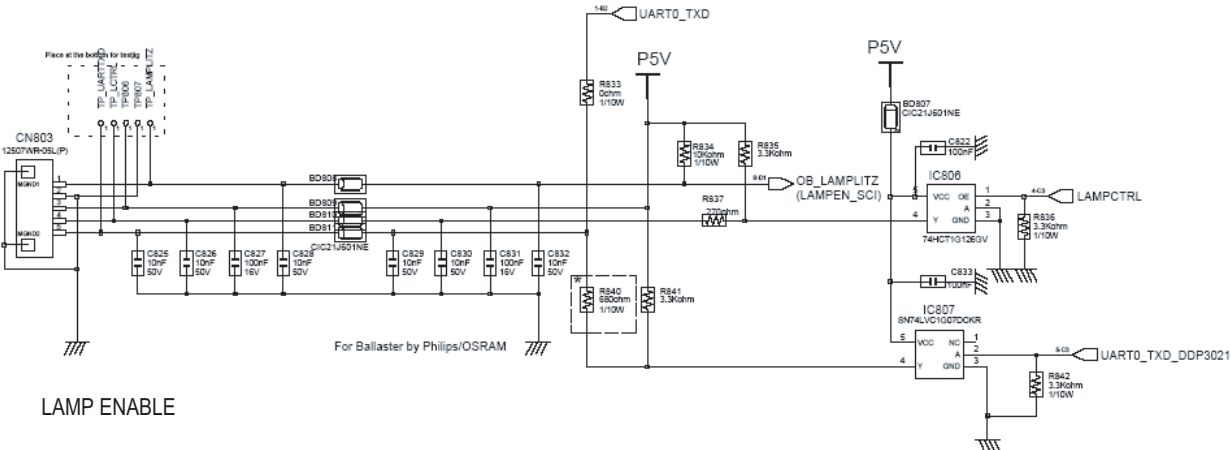

### 6-3-3 DDP3021 Electronics Debugging Flow Diagram

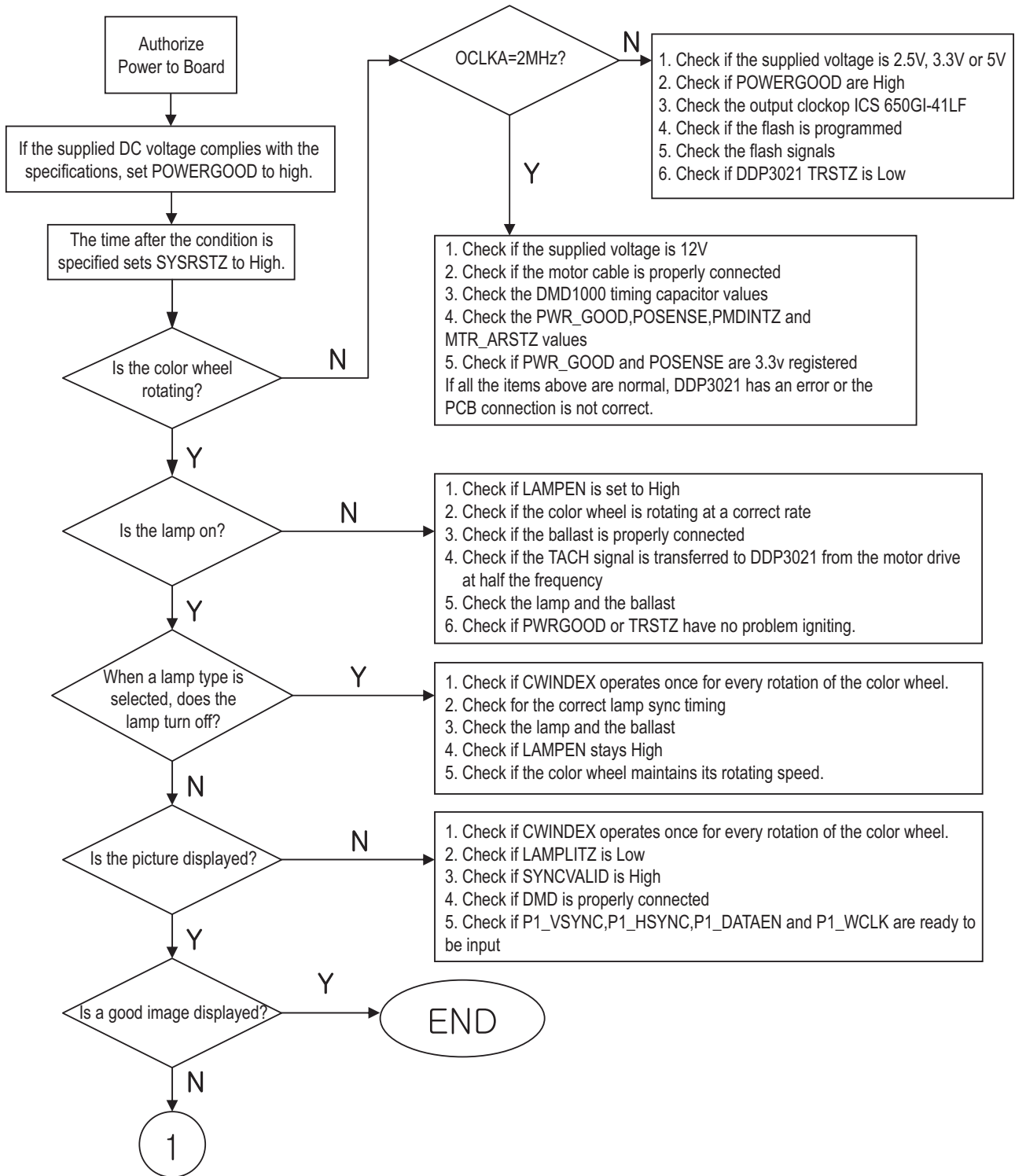

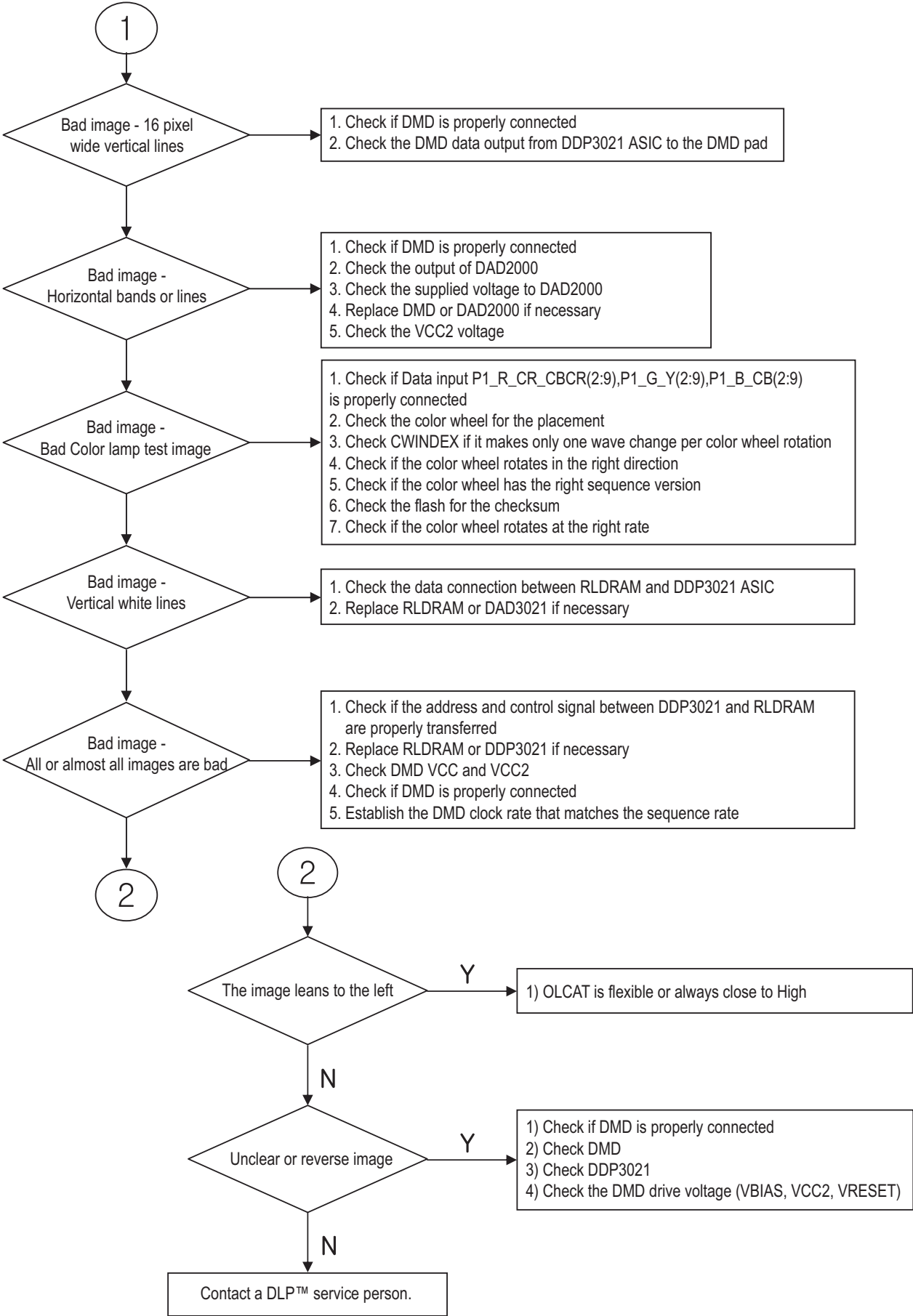

# MEMO